



**altro**

Updated 04/11/2024



**AL**  
**TRO**

# Altro flooring installation guide

General information and guidance for all products

**AL**  
**TRO**

This publication is designed to provide technical information to assist in the installation of Altro flooring. Except where noted, this information applies to the complete range of Altro floor covering products, referred to throughout this guide as Altro floor covering. *Please note installation information specific to individual Altro products.*

The recommendations herein are derived from actual field and laboratory testing by Altro's technical specialists, combined with the recommendations of the Resilient Floor Covering Institute. The procedures are widely accepted in the floor covering industry.

Install Altro floor covering according to the definition of standards in this guide. Any deviations from this definition of standards are to be attempted solely at the risk of those specifying or attempting the actual installation, and are not the responsibility of Altro or its distributors.

Bidding and installation of any Altro commercial flooring products should only be undertaken by professional floor covering installers versed in the required tools and techniques for professional installations. Failure to correctly install Altro floor covering will void the Limited Product Warranty.

## Technical Department

Our technical department, product knowledge and flooring expertise is what sets Altro apart from our competitors. We are here for you every step of the way from planning, through installation and even maintenance for the expected life of the floor.



**Michael Hafferty**  
USA  
mhafferty@altro.com



**Brad Schaible**  
USA  
bschaible@altro.com



**Scott Vigil**  
USA  
svigil@altro.com



**Nick Stein**  
USA  
nstein@altro.com



**John Loupelle**  
Canada  
jloupelle@altro.com



**Carl Bredl**  
USA  
cbredl@altro.com



**Lesley Da Silva**  
Internal Support  
ldasilva@altro.com  
800.377.5597 ext. 3239



**Skip Johnson**  
Technical Manager  
sjohnson@altro.com



**Chris Kephals**  
General Manager  
ckephals@altro.com

## Join us at the Altro Training Academy!

The goal of the Altro training academy is to train and qualify a network of professional flooring installers who wish to become part of a specialized group of recommended Altro installers and fitters.

The floors clinic is ideal for journeyman or above skill levels. Attendees are expected to have previous floor laying knowledge.

Altro stands behind our installers and always recommends that customers use Altro trained installers.

### Three training centers

- Wilmington, MA USA
- Santa Fe Springs, CA USA
- Mississauga, ON, CAN

### Course content

- Adhesive application
- Scribing and trimming
- Corners
- Heat welding
- Flash coving
- Integrated drains
- Best practices
- Advanced wet area training



Contact Lesley for more information or to register for a class!



# Contents

## Chapter 1

### Product overview 4

- 1.1 Safety sheet flooring 5
- 1.2 Slip-resistant sheet flooring 5
- 1.3 Smooth sheet flooring 5
- 1.4 Adhesive-free sheet flooring 5
- 1.5 Plank and tile flooring 5
- 1.6 Altro Everlay 5
- 1.7 Altro Acoustic Underlay 1101 5
- 1.8 Altro Walkway 20SD 5
- 1.9 Altro Ollero 5
- 1.10 Altro Promenade 5

## Chapter 2

### Limitations, storage and handling 6

- 2.1 Product limitations 7
- 2.2 Storage and handling 7

## Chapter 3

### Site conditions and moisture testing 8

- 3.1 Job site conditions 9
- 3.2 Moisture testing 9

## Chapter 4

### Subfloors, radiant heat and existing flooring 12

- 4.1 Substrates 13
- 4.2 Wood subfloors 13
- 4.3 Concrete subfloors 13
- 4.4 Metal subfloors 14
- 4.5 Radiant heat subfloors 14
- 4.6 Existing flooring and adhesive residue 15

## Chapter 5

### System accessories 16

- 5.1 Cap strips 17
- 5.2 Visedge 18
- 5.3 Cove former 19
- 5.4 Joint cover strips 19

- 5.5 Shower transition strip 19
- 5.6 Gulley edge and gulley angle 20
- 5.7 Finishing details 23

## Chapter 6

### Adhesives, sealants, tapes and AltroMastic 100 24

- 6.1 Adhesive recommendations 25
- 6.2 Polyurethane adhesives 27
- 6.3 1-part hybrid urethane adhesive 27
- 6.4 Spray adhesives 27
- 6.5 Acrylic adhesives 27
- 6.6 Static conductive adhesive 27
- 6.7 Contact tape 27
- 6.8 Altro adhesive-free floor system approved installation tape 27
- 6.9 Important adhesive terms 27
- 6.10 AltroMastic 100 29

## Chapter 7

### General sheet vinyl installation procedures 30

- 7.1 General recommendations 31
- 7.2 Subfloor preparation 31
- 7.3 Cutting, fitting and laying 31
- 7.4 Sheet floor seaming 32
- 7.5 Adhesive application 32
- 7.6 Flash coving 33
- 7.7 Forming corners 33
- 7.8 Seam grooving 36

## Chapter 8

### Heat welding 37

- 8.1 Welding seams 38
- 8.2 Trimming seams 38
- 8.3 Welding corners 38

## Chapter 9

### CeGe® Green cold welding 40

- 9.1 CeGe® Green instructions 41

## Chapter 10

### Drains and cleanouts 42

- 10.1 ICC-ES PMG product certification 43
- 10.2 New drains, cleanouts, trenches and floor sinks 44
- 10.3 Modifying an existing drain or cleanout 47
- 10.4 Installation of gulley edge/angle 48

## Chapter 11

### Installing in cold environments 50

- 11.1 Freezers and coolers 51

## Chapter 12

### Repairs and maintenance 52

- 12.1 Repairs 53
- 12.2 Maintenance for sheet vinyl 53
- 12.3 Recommended maintenance products 55



Purchase Altro accessories, maintenance products and tools online today at [www.altrostore.com](http://www.altrostore.com)

# Chapter 1

## Product overview

---

### Topics

- |                                     |                                    |
|-------------------------------------|------------------------------------|
| 1.1 Safety sheet flooring 5         | 1.6 Altro Everlay 5                |
| 1.2 Slip-resistant sheet flooring 5 | 1.7 Altro Acoustic Underlay 1101 5 |
| 1.3 Smooth sheet flooring 5         | 1.8 Altro Walkway 20SD 5           |
| 1.4 Adhesive-free sheet flooring 5  | 1.8 Altro Ollero 5                 |
| 1.5 Plank and tile flooring 5       | 1.10 Altro Promenade 5             |



## 1.1 Safety sheet flooring

**Altro Stronghold 30, Altro Classic 25, Altro Atlas 40, Altro Aquarius, Altro Marine 20**

Areas like busy commercial kitchens and wet environments have additional contaminants, which are continuously present and spillages cannot be avoided. The likelihood of a slip is significantly increased, raising the slip risk level to “extremely high”. These locations demand safety flooring that retains a slip risk level of one in a million with contaminants such as grease, oil, shampoo and shower gels.

## 1.2 Slip-resistant sheet flooring

**Altro Reliance 25, Altro Walkway 20, Altro Illustra, Altro Walkway 20SD, (For Altro Promenade see 1.10)**

In many commercial areas your slip risk is not as high as the specialist area types described above. But, your patrons, patients, students and employees still deserve to be secure on their feet — and you deserve peace of mind. We offer slip-resistant flooring that meets and exceeds safety standards. It reduces the risk of slips and falls and looks good doing so. It has become a practical and durable commercial flooring solution in a variety of application areas.

\*Altro Illustra is not intended for wet environments.

## 1.3 Smooth sheet flooring

**Altro Symphonia, Altro Orchestra, Altro Operetta, Altro Serenade, Altro Wood, Altro Wood Comfort, Altro Wood Acoustic, Altro Cantata, Altro Zodiac Smooth**

Altro smooth flooring has had a significant makeover. Featuring looks that offer versatile, flexible designs that are easy to maintain and install. Most of our smooth color palette has been hand selected to coordinate and contrast with our wall panels and safety flooring, and slip-resistant flooring ranges.

## 1.4 Adhesive-free sheet flooring

**Altro Cantata, Altro XpressLay, Altro Wood adhesive-free**

With our slip-resistant and smooth sheet options your installation becomes simple, quick and effective. Our adhesive-free flooring was created with speed in mind, capable of being installed and walked on within 24 hours — saving you time, money and hassle.

## 1.5 Plank and tile flooring

**Altro Lavencia LVT, Altro Quartz Tile, Altro Dolce Tile, Altro Dolce Essentials**

Altro's plank and tile flooring provide attractive designs that are easy to maintain and install. Whether it's looks, durability or life cycle costs that concern you, our flooring delivers on every count and are suitable for a wide array of application areas.

## 1.6 Altro Everlay (Underlayment)

Altro Everlay is an impervious sheet vinyl underlayment designed to overcome the problems that can be encountered when laying Altro high performance sheet floor coverings over certain damp surfaces, existing resilient flooring, or subfloors contaminated with oil, paint or old adhesive residue. See Altro Everlay QuickFacts for additional information

## 1.7 Altro Acoustic Underlay 1101

Altro Acoustic Underlay 1101 is an impervious sheet vinyl underlayment designed to further reduce the passage and transmission of sound (schools, healthcare, senior living, residences, etc.) See Altro Acoustic Underlay 1101 for additional information.

## 1.8 Altro Walkway 20SD (Static-dissipative flooring)

Static-dissipative slip-resistant flooring for electrically sensitive environments. See Altro Walkway 20SD QuickFacts for additional information.

## 1.9 Altro Ollero (Rubber tile)

Altro Ollero is a versatile, durable and eco-friendly rubber flooring solution designed to provide the look of more traditional commercial surfaces such as carpet, stone and even cork. Available in a range of 22 colors with a mixture of solid, speckled, neutral and vibrant tones, these tiles are guaranteed not to curl, harden or crack over time. Their integrated impact and sound absorption properties can help reduce fatigue and excess noise in high traffic areas. See Altro Ollero installation instructions for additional information.

## 1.10 Altro Promenade (Exterior flooring)

Designed for outdoor functionality, Altro Promenade sheet vinyl flooring provides essential slip resistance in areas exposed year-round to changing weather conditions. Available in four different patterns, this range is ideal for patios, decks and pool surrounds that prioritize both safety and aesthetic appeal. See Altro Promenade installation instructions for additional information.

# Chapter 2

## Limitations, storage and handling

---

### Topics

2.1 Product limitations 7

2.2 Storage and handling 7

## 2.1 Product limitations

Altro products are not recommended in the following areas:

- Areas exposed to certain conditions that may cause staining. For example, areas such as newly applied asphalt in driveways or parking lots, or antioxidants in certain types of rubber used in mats, wheels, and tires. Certain dark colors of Altro flooring or products with Altro Easyclean Technology may minimize this effect.
- Areas which may be subjected to hot objects that may burn or melt vinyl flooring. Vinyl floor covering must be protected from excessive heat, or items exceeding 140°F (60°C).
- Areas where forklifts and/or pallet jacks travel at high speed, since friction caused by the tires can lead to surface damage from tire burn.
- Areas where the presence of sharp items, such as nails protruding from pallets or other objects, could cause severe physical damage.
- Areas subject to excessive spillages of alcohol, ketones or other solvents harmful to vinyl.
- The use of inappropriate, improperly designed, or inadequate floor protection devices. It is the responsibility of the equipment manufacturer to provide suitable floor contacts to prevent indentation or delamination.
- Areas directly underneath hospital bed wheels, or the point load of heavy equipment, should be installed with Altro EcoFix+ with a fine notched trowel. Please consult Technical Services for installation methods.
- Areas with excessive moisture.
- It is the responsibility of the end-user/maintenance provider to assure excessive water does not penetrate or damage the finished flooring.
- In areas subjected to severe surface moisture after installation, or where at least one floor drain exists, Altro safety flooring must be installed with AltroFix 30 two-part polyurethane adhesive. Contact an Altro representative for installation information concerning these areas.
- Minimum operating temperatures should not drop below -22°F (-30°C) for Altro Stronghold 30 and -4°F (-20°C) for all other Altro slip-resistant and safety flooring products.
- DO NOT use markers (sharpies, pens, construction crayons, etc.), tapes or paints (construction or other) on the flooring or on the substrate as these items may bleed through or otherwise cause permanent staining.
- Use only recommended cleaning chemicals or their equivalent in the correct dilution. Do not mix two different cleaning products together, and always follow the manufacturer's instructions. Always

check the suitability of cleaners for use on vinyl floors with the chemical manufacturer. Do not use cleaner containing pine oil, phenolic sanitizer, or enzyme cleaners that will be left on the surface of the flooring.

- Altro assumes no liability for damage to our flooring resulting from the misuse or improper use of markers, paints, or maintenance products. Please confirm with the manufacturer of all tape, cleaning products chemicals and equipment for their recommendations.

Please contact your local Altro distributor for advice regarding any of the above.

## 2.2 Storage and handling

If storage temperature is below 68°F (20°C), Altro floor covering must be moved to a warmer place and allowed to reach this temperature before unrolling. The room temperature must not be below 68°F (20°C) and the sub-floor temperature between 65°F (18°C) and 80°F (27°C).

- Rolls of Altro floor covering must be stored in dry conditions and stood upright on a level floor. If stacked horizontally, there is a risk of "flattened areas" developing which can lead to installation difficulties.
- Safety precautions should be taken to secure rolls standing on end to prevent them from accidentally falling.
- Store all cartons of tile and plank on a dry flat level surface, carefully stacked squarely on top of each other.
- Many of the Altro floor covering ranges incorporate a colored quartz aggregate in the material. Eye protection should be used and care taken during cutting and grooving procedures.
- If more than one roll is used, unroll the flooring in numeric sequence.
- Sheet flooring should be unrolled with the decorative side up. It should be left unrolled for at least 10 minutes, then back-rolled loosely and again unrolled to eliminate any stress in the material.
- Flooring must be checked for defects before installation.
- When installing flooring, check carefully to see that drops match in shade. It may be necessary to reverse sheets of Altro floor covering to obtain a side shade match. If a side shade match cannot be accomplished, do not install. Contact your Altro distributor.
- Caution should be used in moving and lifting of rolls. Allow for appropriate equipment and manpower to safely move materials.
- When installing tiles the tiles should all be of the same dye-lot / batch number.
- Do not install flooring with visible defects.



# Chapter 3

## Site conditions and moisture testing

---

### Topics

3.1 Job site conditions 9

3.2 Moisture testing 9

### 3.1 Job site conditions

- Before job testing, the building envelope must be sealed and weather tight (walls, roofing, windows, doorways etc.).
- The installation of floor covering must not begin until work of all other trades has been completed.
- Building HVAC must be up and running and in permanent operation prior to installation. A minimum temperature of 68°F (20°C) must be maintained for at least 72 hours before, during, and there after.
- The installation area and Altro materials must be maintained and installed at a minimum of 68°F (20°C) and a maximum of 85°F (29°C) Slab temperature should be between 65°F (18°C) and 80°F (27°C). Altro Ollero must be maintained and installed between temperatures of 57°F(14°C) and 72°F (23°C). Relative humidity level extremes should also be avoided.
- All materials and subfloors must be fully acclimated to installation temperature.
- The areas of installation must be adequately lighted to allow for proper inspection of the flooring and subfloor. This is especially critical when flash coving.
- Area of installation must not be within 5 degrees of dew point. Please reference the enclosed dew point chart. Low relative humidity (dry air) must exist and be maintained during the application of adhesive. Installations must not take place when the substrate of the area of installation is within 5 degrees of dew point.
- Moisture tests must be taken to ensure the subfloor is sufficiently dry for the installation of the Altro floor covering. Please see 2.2 Moisture testing on page 9.
- Prior to starting the installation please advise the general contractor and/or end user about the subfloor moisture requirements, all applicable job site, and site storage requirements that will be needed at time of installation.
- Remember if you cover a subfloor, underlayment or other surface with floor covering, you have, in essence, approved it.
- All traffic must remain off finished floors for 24 hours before light traffic, 48 hours before light rolling loads, and 72 hours before heavy loads are allowed.

#### Dew points and humidity

Dew point is the temperature at which the humidity in the air begins to condense in and on a surface. Floor coverings and adhesives should not be installed any time the air temperature or concrete surface temperature is within five degrees of dew point. See the chart below for a breakdown of dew points in different conditions.

#### Dew point temperature in Fahrenheit

	Relative humidity									
	10%	20%	30%	40%	50%	60%	70%	80%	90%	100%
Air temp (F)	Dew point (concrete surface temperature)									
40	5	8	14	18	24	28	31	34	37	40
45	5	9	16	23	28	32	36	39	42	45
50	6	13	21	27	33	36	40	44	47	50
55	8	16	25	31	36	41	45	49	52	55
60	9	20	29	35	41	46	50	54	57	60
65	10	24	33	40	46	51	55	58	62	65
70	13	28	37	45	50	55	60	64	67	70
75	17	31	42	49	55	60	64	68	72	75
80	20	35	46	53	60	65	69	73	77	80
85	24	40	50	58	64	69	74	78	82	85
90	27	43	54	62	69	74	79	83	87	90
95	30	48	59	67	73	79	84	88	92	95
100	34	52	62	71	78	83	88	93	97	100

### Procedure to determining a dew point

- Test and read the air temperature in the room.
- Test and read the relative humidity in the room.
- Test and read the concrete surface temperature.
- Find the air temperature on the accompanying dew point chart. (Left hand side, up and down the chart.)
- Find the relative humidity on the dew point chart. (Top of chart, across.)
- Intersect the air temperature (sideways movement) with the relative humidity (downward movement) on the dew point chart.
- Obtain the figure at this intersection.
- Compare this figure with the concrete surface temperature.
- If these figures are within five degrees of each other, floor covering should not be installed.

## 3.2 Moisture testing

ASTMs may be obtained from [www.astm.org](http://www.astm.org)

Moisture testing is an essential part of determining the suitability of a concrete slab to receive a resilient floor covering. Moisture testing must be performed on all concrete slabs, regardless of their age or grade level, including areas where resilient flooring has already been installed. Moisture testing should be conducted with the area or building at service conditions, (i.e., fully enclosed, weather-tight, and with the permanent HVAC in operation). In general, moisture testing should be conducted on concrete surfaces that exhibit the final prepared stage before the installation of the flooring material and before installation of smoothing or leveling compounds. Test results are only indicators of current moisture conditions at the time of testing and do not predict future moisture conditions.

**NOTE: Moisture failures are generally a complex, cumulative, and synergistic series of events. The moisture testing information below is provided as an industry service and in an effort to help reduce the likelihood of moisture related failures within the floor covering industry.**

**Use the test methods described below to determine the dryness of the subfloor and suitability of surface pH as required to ensure initial and long-term success.**

- Moisture testing determines the moisture conditions at the time of testing only and does not guarantee or preclude the possible future intrusion of moisture.
- All on-grade and below-grade concrete slabs must have an effective moisture vapor barrier that meet the current requirements of ASTM E1745.
- Document and record with all appropriate parties all tests taken for moisture, pH and any other tests taken.
- Alkalinity Testing - Consult Altro adhesive datasheet for

pH limitations. (As a concrete surface reacts with carbon dioxide in air, the pH of the surface gradually is reduced to about 8.5 through a process called carbonation. A concrete slab that is carbonated and ready to receive a flooring adhesive should have a pH of about 8.5. This means the surface of the concrete has had minimal moisture vapor movement. The higher the concrete surface pH the greater this higher pH is an indicator that moisture has recently passed through the concrete and must be tested for.

**NOTE: Altro requires that moisture testing be done per ASTM F2170 and results be within warranted levels. A secondary test of ASTM F1869 can also be done. Results are to be below 8 lbs.**

**Both relative humidity test in accordance to ASTM F2170 and moisture vapor emissions test in accordance to ASTM F1869 must be completed and documented when installing Altro Ollero.**

**The reason for both tests to be done is that the Relative Humidity test tells us how much water is within the concrete (this is the important number and information) and then the Calcium Chloride test tells us how much and how fast this quantity of relative humidity is then evaporating out the top 1/2" to 3/4" inch of the concrete.**

- ASTM F2170 - Standard Test Method for Determining Relative Humidity in Concrete Slab Using in-situ Probes: This test method covers the quantitative determination of percent relative humidity in concrete slabs for field or laboratory test. Conduct one test for every 1,000 square feet (minimum 3 tests) to ensure concrete does not exceed the recommended RH for the flooring product and the adhesive being used. See Adhesive chapter for RH limitations for each Altro adhesive.
- ASTM F1869 - Standard Test Method for Measuring Moisture Vapor Emission Rate of Concrete Subfloor Using Anhydrous Calcium Chloride. This test method covers the quantitative determination of the rate of moisture vapor emitted from below-grade, on-grade, and above-grade (suspended) bare concrete floors. Equal to and not exceeding 8 lbs. / 24 hours / 1000 square feet for all adhesives.
  - To employ F1869, the surface of the concrete must be porous. Hard machine troweled concrete or concrete surfaces with extraneous substances on the surface such as residual adhesive, sealers, curing compounds, etc. must be mechanically removed prior to testing.
  - For moisture readings exceeding the RH limitations and/or exceeding 8 lbs. / 24 hours / 1000 square feet, a dehumidification system shall be utilized until moisture readings when retested are within warranted levels. For excessive readings, the application of a high-quality moisture mitigation system may also be employed. Any warranties and/or guarantees for the performance of the mitigation system are the responsibility of that products manufacturer, not Altro.

### Additional tests

- Mat Moisture Tests and Electric Moisture Meters can be used to detect the presence of moisture, however these test methods do not replace the required testing. When electric meter and/or mat





# Chapter 4

## Subfloors, radiant heat and existing flooring

---

### Topics

4.1 Substrates 13

4.2 Wood subfloors 13

4.3 Concrete subfloors 13

4.4 Metal subfloors 14

4.5 Radiant heat subfloors 14

4.6 Existing flooring and adhesive residue 15





Notes

material. If these contaminants are present on the substrate, they must be mechanically removed prior to installation of the flooring.

- Caution, certain floor sweeping compounds may contain waxes, oils, and/or other substances that can adversely effect the adhesive bond, check with the sweeping compound manufacturer for assurances of suitability and non-contamination.
- The surfaces of the concrete shall be flat to within the equivalent of 3/16" in 10 ft, per ASTM F710.
- Concrete must have a minimum compressive strength of 3500 psi.
- Lightweight concrete (less than 115 lbs per cubic foot) may be unsuitable for covering with resilient flooring.
- Gypsum based substrates and underlayments may be unsuitable.

**Control joints and expansion joints**

There are two types of joints in concrete. The first type is called a control joint and is saw cut into fresh concrete to "control joint" the slab during the curing process. These, along with and other non moving joints, should be vacuumed cleaned then filled with an elastomeric compound or an acceptable portland based leveling compound.

An alternative would be to install a joint cover strip when there is a potential of control joints showing through the finished flooring.

The second, and most difficult type of joint, is an actual "expansion joint." Most flooring manufacturers do not recommend bridging these joints with their material.

Altro does not recommend that flooring products be installed over joints designed for continued movement we recommend the use of appropriate expansion joint cover.

**4.4 Metal subfloors**

Suitable metal substrates may include:

- Clean, rigid steel
- Primed steel
- Steel diamond plate
- Galvanized steel
- Lead
- Metal subfloors must be clean, rigid, and free from all rust, oil, grease, coatings and all other contaminants.
- Diamond Plate will require a smoothing and leveling compound be used; please consult with your local underlayment/patch company for appropriate product recommendations and statement of product suitability.
- In certain circumstances lead as a subfloor may be

too soft for the intended use.

- Cleaning/preparation may consist of sanding, grinding, cleaning with TSP (trisodium phosphate), and priming with red oxide primer such as Rust-OLEUM®.
- Joints can be filled and made smooth using AltroFix 30/31 two-part polyurethane adhesive when the finished flooring is to be installed with the same two-part polyurethane adhesive.
- In some instances (such as certain coolers and freezers), when metal panels are prone to movement, Altro Everlay "A" sheet underlayment will be used to allow the installation of finished flooring.
- Final determination of the suitability rests with the flooring contractor.

**4.5 Radiant heat subfloors**

**Altro flooring and underfloor heating**

In the past, Altro used to recommend a maximum figure for underfloor heating of 85°F (30°C) without any reported problems. However, due to the concerns of flooring manufacturers that some underfloor heating systems could operate at up to 95°F (35°C), Altro recommends that the following guidelines be followed.

- Before any floor covering is installed, the heating system should be commissioned to ensure it is functioning correctly, and to ensure the substrate and screed is dry and in a stable state to receive the flooring. When the subfloor/screed containing the heating system has been laid, cured and dried, prior to installing the flooring, it should be heated very slowly to its operating temperature and maintained for several days before cooling down to room temperature, but not below 60°F (15°C).
- Ensure that the underfloor heating is switched off 48 hours prior to the floor covering installation commencing and remains off for at least 48 hours after the installation is complete.
- The temperature of the heating system should be increased gradually over a number of days, by only a few degrees per day, until the desired room temperature is reached. The temperature at the underside of the floor covering, i.e. the adhesive line, should never exceed the maximum of 80°F (27°C).
- During the period of decommissioning and shutting down of the underfloor heating system, an alternative heating source should be provided, if required, to ensure that the area of installation is kept at a constant temperature between 65°F (18°C) - 80°F (27°C).



# Chapter 5

## System accessories

---

### Topics

5.1 Cap strips 17

5.2 Visedge 18

5.3 Cove former 19

5.4 Joint cover strips 19

5.5 Shower transition strip 19

5.6 Gulley edge and gulley angle 20

5.7 Finishing details 23



## 5.2 Visedge

Visedge VR is an aluminum alloy trim with a co-extruded locking PVC insert and flexible PVC strip for welding to vinyl flooring. Use the pre-drilled holes to secure the strip to the subfloor, the appropriate screws and anchors must be used for the type of installation. Additionally, AltroFix MP600 must be used under the edge to keep water from traveling back under the flooring. A patching/leveling compound needs to be used, to accommodate the thickness of the edging.

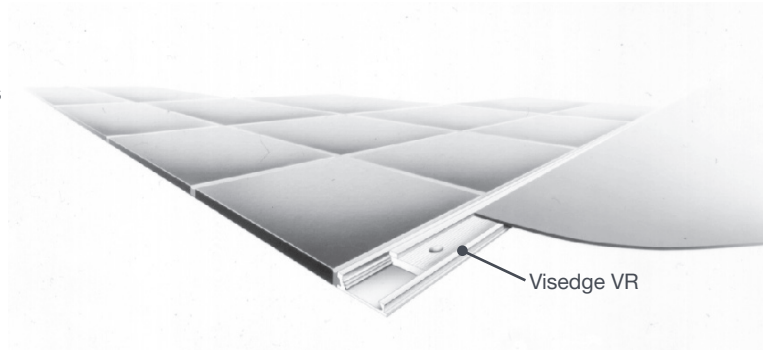
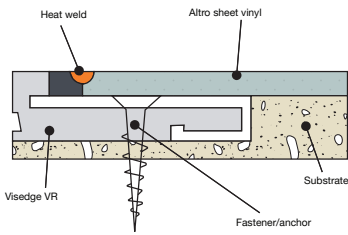

Visedge VR vinyl securing strip diagram

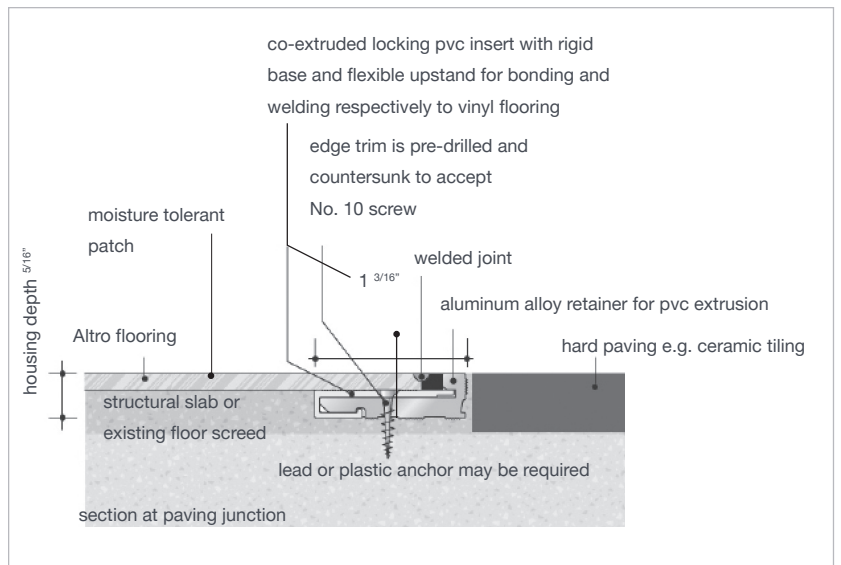
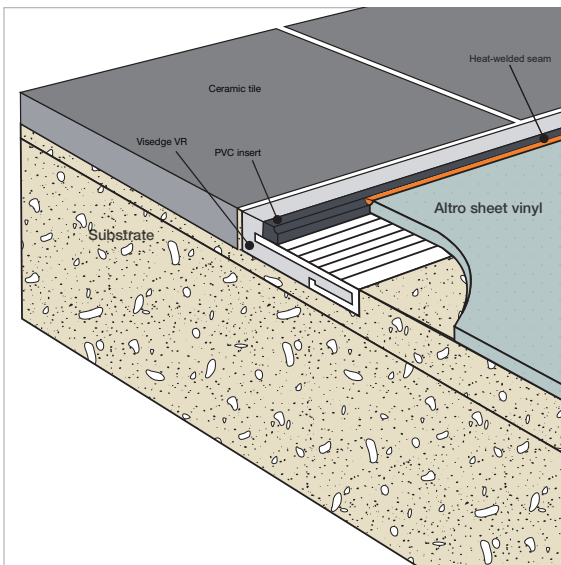





Notes

### 5.3 Cove former

Used to create flash coving with resilient sheet flooring.

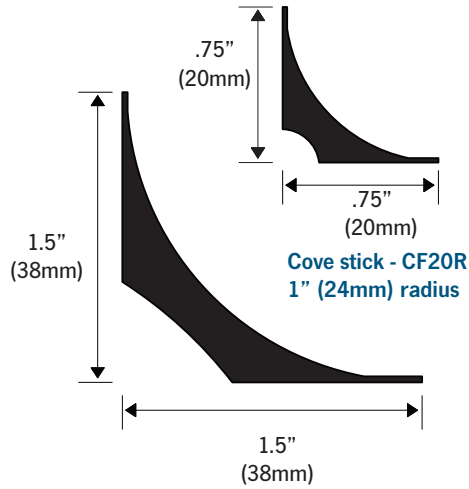

**Cove stick - CF38R**  
1.75" (45mm) radius

### 5.4 Joint cover strips

Cover strip used when there is potential of control joints moving and showing through the finished floor.

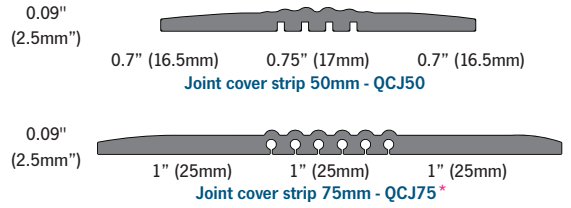

\* Available in Grey, use code QCJ50/LIGHTGREY

### 5.5 Shower transition strip

Wheel chair accessible shower berm that prevents water egress from wet areas.



**Shower transition trim - ASF WETTRIM**

## 5.6 Gulley edge and gulley angle

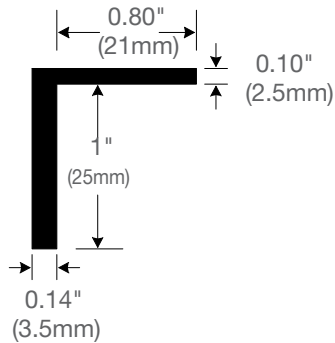

Altro gulley angle - GA35/25

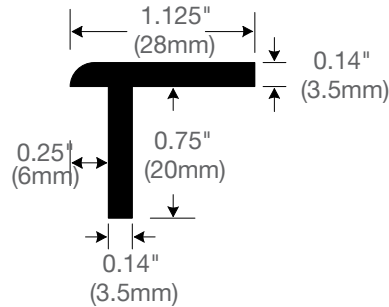

Altro gulley edge - GE 35RE

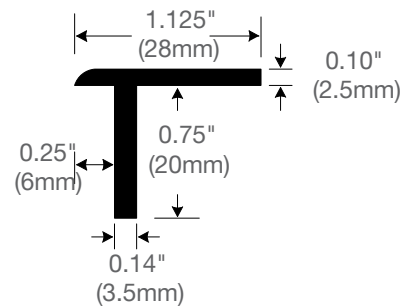

Altro gulley edge - GE 25RE

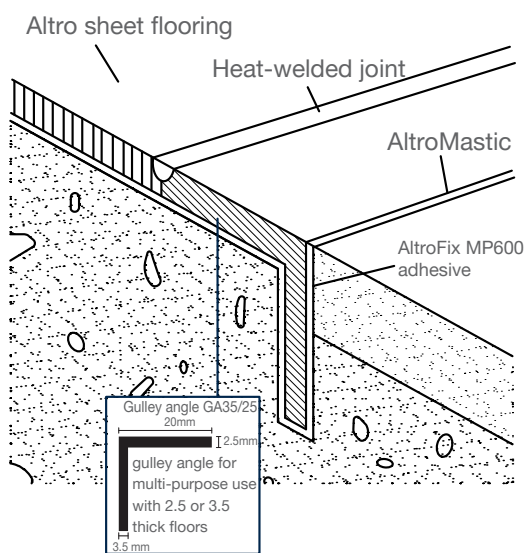

Altro gulley angle - GA35/25

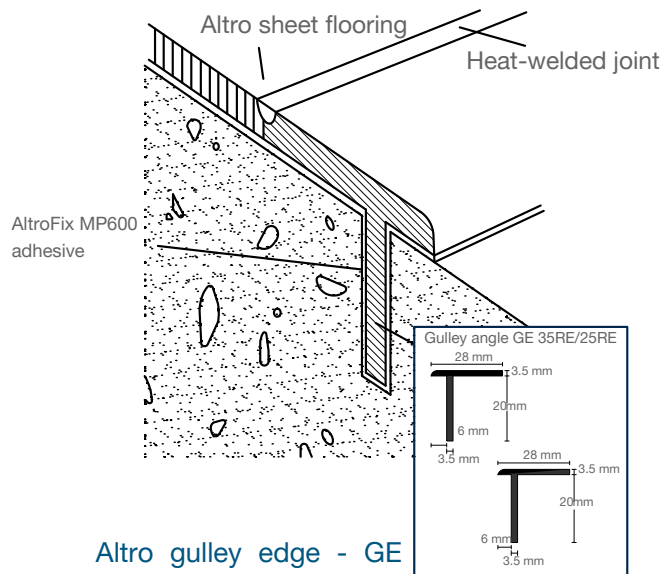

Altro gulley edge - GE 25RE  
Altro gulley edge - GE 35RE

See section 9.3 for gulley edge and angle installation instructions.

Notes

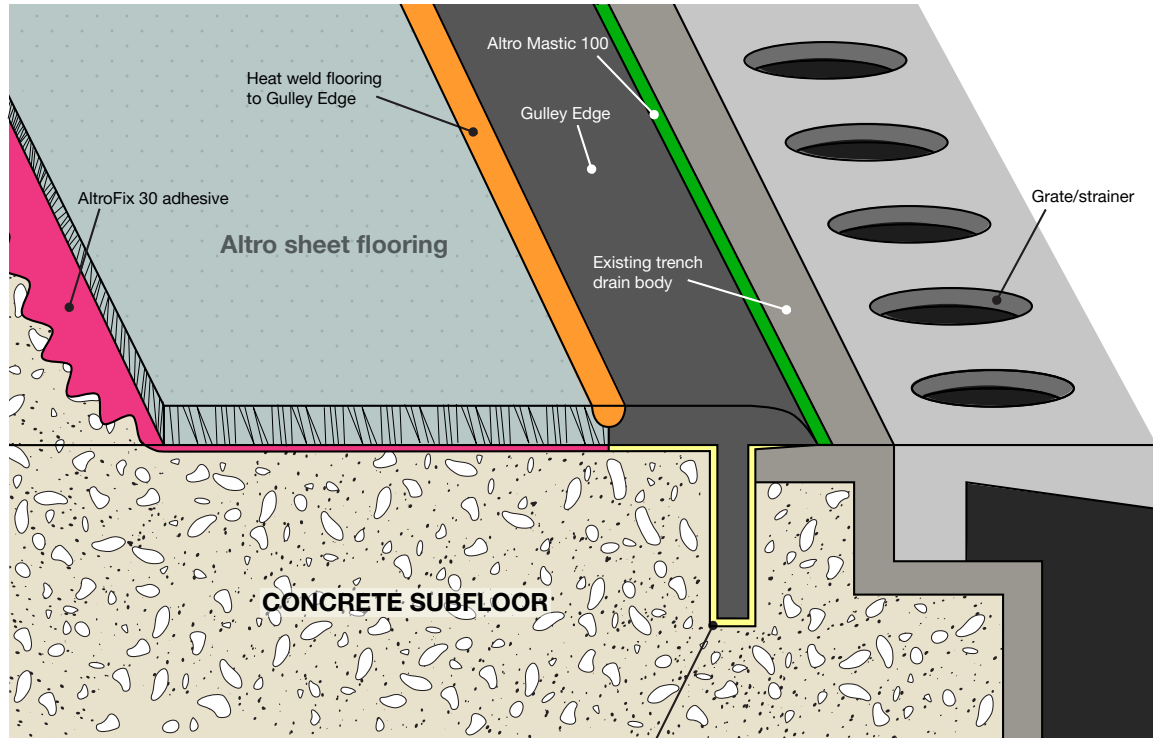

AltroFix MP600 adhesive to be applied to concrete substrate and into saw cut to properly adhere Gulley Edge

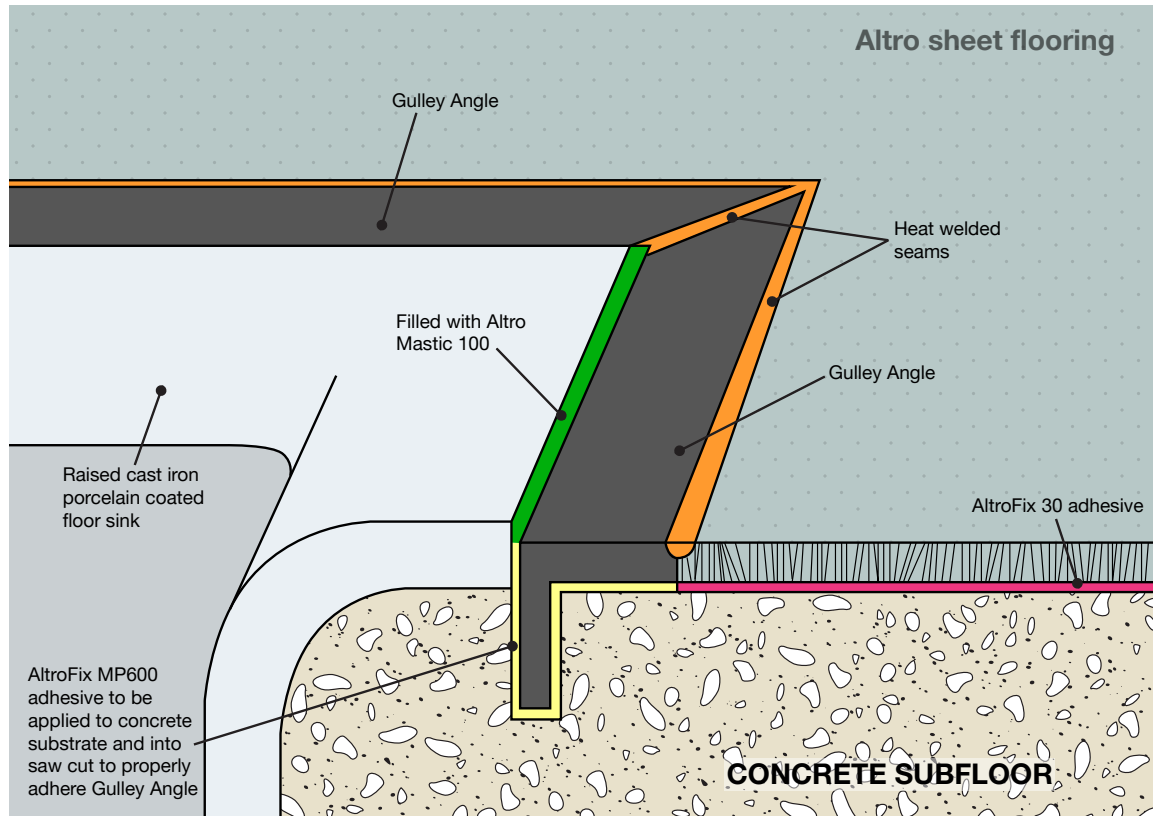

## 5.7 Finishing details

Notes \_\_\_\_\_  
 \_\_\_\_\_  
 \_\_\_\_\_  
 \_\_\_\_\_  
 \_\_\_\_\_  
 \_\_\_\_\_  
 \_\_\_\_\_  
 \_\_\_\_\_  
 \_\_\_\_\_  
 \_\_\_\_\_  
 \_\_\_\_\_  
 \_\_\_\_\_  
 \_\_\_\_\_  
 \_\_\_\_\_  
 \_\_\_\_\_  
 \_\_\_\_\_  
 \_\_\_\_\_  
 \_\_\_\_\_  
 \_\_\_\_\_  
 \_\_\_\_\_  
 \_\_\_\_\_

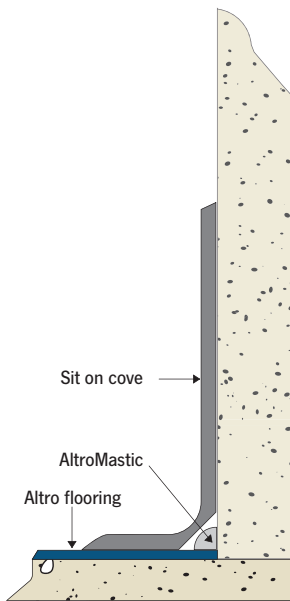

**Sit on cove detail**  
(Dry environments only)

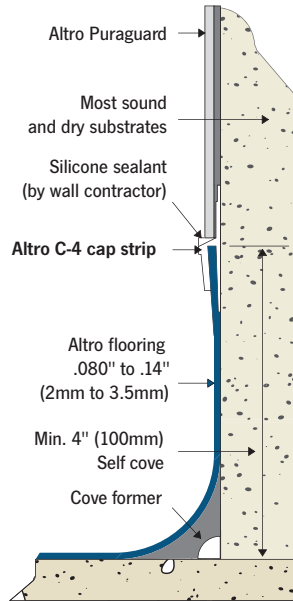

**C-4 detail**

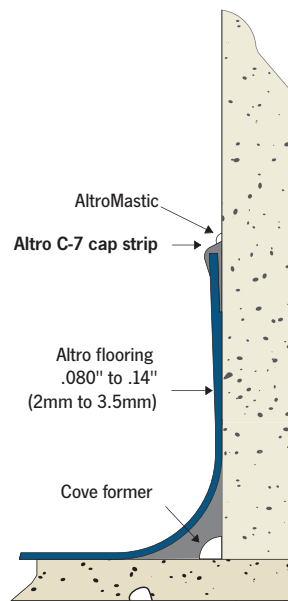

**C-7 detail**  
(Dry environments only)

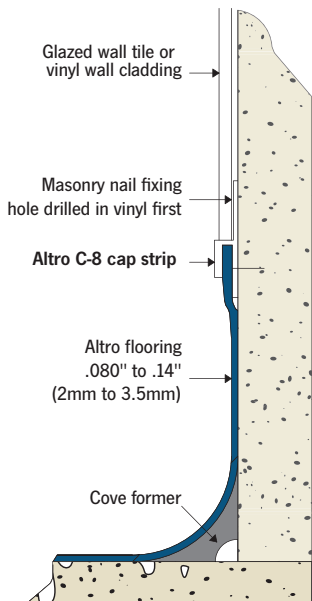

**C-8 detail**

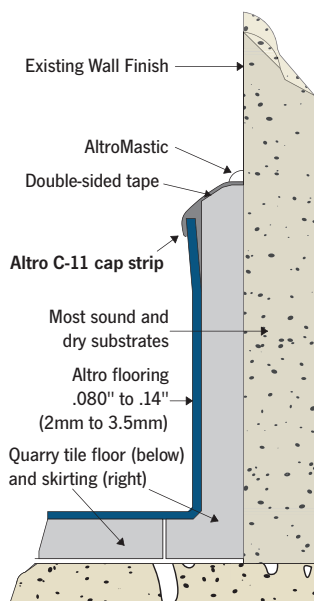

**C-11 detail**  
(Dry environments only)

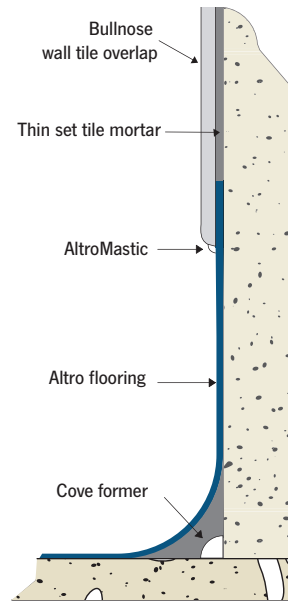

**Bullnose wall tile overlap detail**

C7, Stainless Steel, Aluminum or standard cap from other manufacturers are inappropriate caps to use in wet applications. In all wet floor and wall applications (showers, kitchens, cart wash areas, etcetera), the overlap detailing method is the recommended and preferred finishing method, although C4 or C8 cap can be used when an appropriate wall cladding is also specified and used.

# Chapter 6

## Adhesives, sealants, tapes and AltroMastic 100

---

### Topics

- 6.1 Adhesive recommendations 25
- 6.2 Polyurethane adhesives 27
- 6.3 1-part hybrid urethane adhesive 27
- 6.4 Spray adhesives 27
- 6.5 Acrylic adhesives 27
- 6.6 Static conductive adhesive 27
- 6.7 Contact tape 27
- 6.8 Altro adhesive-free floor system approved installation tape 27
- 6.9 Important adhesive terms 27
- 6.10 AltroMastic 100 29

## 6.1 Adhesive recommendations

Notes

Product	Porous (absorbent) subfloors (most wood subfloors and some concrete)	Non-porous (non-absorbent) Subfloors (most concrete, ceramic, terrazzo, moisture sealers, metal and existing flooring)
Safety sheet flooring	AltroFix 30/31 (excessively heavy rolling loads and/or excessively wet areas) EcoFix 35 spray (dry areas) EcoFix+ (dry areas) AltroFix ZERO	AltroFix 30/31 (excessively heavy rolling loads and/or excessively wet areas) EcoFix 35 spray (dry areas) EcoFix+ (dry areas) AltroFix ZERO
Smooth sheet flooring	EcoFix 35 spray (dry areas) EcoFix+ AltroFix ZERO (For heavy rolling loads contact Altro Technical Services.)	EcoFix 35 spray (dry areas) EcoFix+ AltroFix ZERO (For heavy rolling loads contact Altro Technical Services.)
Adhesive-free flooring	Altro adhesive-free floor system approved installation tape	Altro adhesive-free floor system approved installation tape
Altro Ollero	Altro adhesive for rubber flooring	Altro adhesive for rubber flooring
Altro Walkway 20 SD	AltroFix SD70 Conductive Acrylic	AltroFix SD70 Conductive Acrylic
Tile + LVT	Ecofix 65 Spray EcoFix+	Ecofix 65 Spray EcoFix+
Gulley angle/edges	AltroFix MP600	AltroFix MP600

Most concrete is considered to be non-porous (non-absorbent). To test for porosity, sprinkle a few drops of water on the subfloor, and if it is not absorbed within about one (1) minute, the subfloor should be treated as a non-porous/low absorbency surface. The final determination for subfloor porosity is the responsibility of the flooring contractor.

Please note:

- Adhesive coverage is only an approximation based on experience, manufacturers recommendations, and subfloor porosity, Altro does not warrant nor guarantee actual adhesive coverages.
- AltroFix 31 is a faster setting polyurethane adhesive and can also be used for repair and small installations of sheet material requiring a quicker set time than a two-part polyurethane adhesive.
- AltroFix MP600 adhesive is the recommended adhesive choice for gulley edge/angle, alternatively AltroFix 30/31 adhesives can be used.
- Adhesive bond tests must be conducted with the flooring and adhesive specified to determine the compatibility of the adhesive with the prepared subfloor.
- Ecofix+ adhesive is acceptable up to 99% RH, Ecofix 65 Spray and 35 Spray are acceptable to 98% RH and Altrofix30/31 is acceptable up to 90% RH. AltroFix ZERO has no moisture limitations.
- For coved areas of flooring, Altro Contact tape is used to adhere coving for both porous and non-porous applications.
- Adhesive bond tests must be conducted with the flooring and adhesive specified to determine the compatibility of the adhesive with the prepared subfloor.



Notes

**Altro adhesives – description chart**

Adhesive	Description	Trowel size	Coverage*
AltroFix 30	2-part Polyurethane (wet set)	1/32" x 1/16" x 1/32"	Approx. 150 sq ft per gallon
AltroFix 31	2-part Polyurethane (wet set)	1/32" x 1/16" x 1/32"	Approx. 150 sq ft per gallon
AltroFix ZERO	1-part hybrid urethane adhesive	1/32" x 1/16" x 1/32"	Approx. 131 - 180 sq ft per gallon
AltroFix SD70	Conductive Acrylic	1/16" x 1/16" x 1/16"	Approx. 80 sq ft per gallon
EcoFix 65	Acrylic Spray Adhesive	-	Approx. 150 to 185 sq ft per bottle
EcoFix 35	Acrylic Spray Adhesive	-	Approx. 150 to 185 sq ft per bottle
EcoFix+	Hybrid acrylic formulation	1/32" x 1/16" x 1/32"	Approx. 220 - 260 sq ft per gallon
AltroFix MP600	1-part high quality fast curing MS polymer adhesive	-	-
Altro adhesive for rubber flooring	Single component moisture cure polyurethane adhesive	1/16" x 1/16" x 1/16" V- Notch	Approx. 100 sq ft per gallon
Contact Tape	For use in adhering coved areas in flooring installation 1", 4" and 6"	-	50 m / 164 ft

\*Adhesive coverage is only an approximation based on experience, manufacturers recommendations, and subfloor texture and porosity, Altro does not warrant nor guarantee actual adhesive coverages.

**Trowel size**

Tile notch of 1/32" deep x 1/16" wide x 1/32" apart.

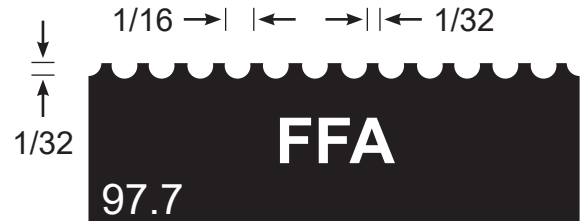

## 6.2 Polyurethane adhesives

### AltroFix 30 and AltroFix 31

For installations of Safety Sheet Flooring in areas subjected to excessive spillage of water, floors with a drain(s), extreme temperature change, and extremely heavy rolling loads, AltroFix 30 adhesive is mandatory. AltroFix 31 is an extremely fast setting version of AltroFix 30.

Polyurethane adhesives, also known as reactive adhesives, are suitable for all approved subfloors including properly prepared metal. Polyurethane adhesives are generally not suitable for vertical surfaces due to their low initial grab.

## 6.3 1-part hybrid urethane adhesive

### AltroFix Zero

AltroFix™ ZERO offers an effective solution to halt moisture-related delays. Crafted using a secure, single-part, moisture-curing formula, AltroFix™ ZERO presents a swifter and more user-friendly option compared to two-component epoxy systems. This 1-part hybrid urethane is expertly designed to withstand heavy rolling loads and the demanding conditions of wet environments.

## 6.4 Spray adhesives

### EcoFix 65 Spray

Used for adhering tile and/or plank products in commercial and residential applications.

### EcoFix 35 Spray

Used for adhering resilient sheet vinyl products in commercial and residential applications.

**NOTE:** Spray adhesives are not freeze-thaw stable.

## 6.5 Acrylic adhesives

### EcoFix+

Transitional pressure sensitive adhesive (TPSA) goes above and beyond by withstanding severe moisture and alkalinity. Offering the upfront benefits of a TPSA, it quickly transitions into a hard-set to securely lock your flooring in place. With its aggressive, fast-grab design, Altro EcoFix+ handles the pressure of heavy rolling loads with ease and is suitable adhesive for resilient flooring.

**NOTE:** For use in dry areas.

## 6.6 Static conductive adhesives

A static conductive adhesive must be used with Altro Walkway 20SD, Altro's static dissipative safety flooring.

**NOTE:** Please contact your Altro distributor for the approved static conductive adhesive for specific applications.

## 6.7 Contact tapes

Vinyl cap strips, cove stick, and integral cove may be adhered using a quality contact tape.

## 6.8 Altro adhesive-free floor system approved installation tape

For adhesive-free installation, Altro adhesive-free floor system approved installation tape is used to adhere the sheet vinyl backing to clean, dust free substrates.

## 6.9 Important adhesive terms

Coverage is the amount of adhesive applied to a given surface. To obtain a good bond, the right amount of adhesive has to be applied with the appropriate trowel, in accordance with the manufacturer's recommendations.

If not enough adhesive is applied, the bond will be too weak and there will be insufficient contact between the adhesive and the material. If the substrate is porous and a fluid adhesive is used, the adhesive may be absorbed by the substrate, leaving insufficient coverage for proper bonding. If the surface to be bonded is rough, sufficient adhesive has to be applied to ensure that it penetrates into all the nooks and crannies.

If too much adhesive is applied, water may remain trapped inside and not evaporate properly. As a result, the adhesive will not harden at the proper rate, causing blisters or even ungluing. In addition, too thick an application may result in indentation or pockmark problems.

To obtain the correct coverage, the installer must use the appropriate trowel. Furthermore, the notches of the trowel must not be worn down, which will occur when steel trowels are used on hard substrates. When the notches are worn, the trowel will not apply enough adhesive. Worn-out trowels should be replaced. Renotching is not always a good alternative since labor sometimes costs more than a new trowel. Renotching a trowel or spreader is inconsistent. This will result in an incorrect amount of adhesive being applied and could lead to failure.

Pot life applies only to reactive adhesives (epoxy, polyurethane, polyester, and dry-set mortars). The pot life is the length of time that an adhesive remains usable after the components are mixed. Depending on the product formula, the chemical reaction will begin immediately or soon after mixing.

### Factors affecting pot life include:

**Temperature:** The higher the temperature, the shorter the pot life, since heat accelerates the chemical reaction producing hardening.

**Size of Mixture:** In the case of certain products, an exothermic, or heat-generating reaction occurs, with the amount of heat generated increasing in proportion to the mass of the mixture. If too much product is mixed at one time, the reaction could accelerate substantially, causing the adhesive to set prematurely. Therefore, when working with such products, it is advisable to spread the adhesive in a thin coat. This allows the heat of the reaction to escape, thus prolonging the working time.

Tackifying time is the interval of time between the spreading of the adhesive on the substrate and the installation of the material. During this time, the water begins to evaporate. As a result, the adhesive thickens and becomes tacky, producing sufficient cohesion so that the material can be installed without the risk of it lifting.

The tackifying time for various adhesives on the market ranges between 0 and 40 minutes, depending on the type of formula used.

### Factors affecting the tackifying time include:

**Temperature and humidity:** If it is hot and dry, water will evaporate rapidly and the material must be installed faster. The opposite is true when it is cool and humid.

**Absorbency of substrate:** If the direct glue down method is being used to apply an adhesive in emulsion or solution, the installer must verify the absorbency of the substrate and the material to ensure that the water is able to evaporate out or be absorbed after installation. If not, blistering or bubbling may occur.

Installer must always respect tackifying time.

Open time begins when the adhesive is spread and ends when it loses its adhesive properties. Therefore, the interval of time during which the material can be installed depends on the tackifying and open time, as shown in the diagram:

### Factors affecting the open time include:

**Temperature and humidity:** Heat shortens the open time by accelerating the evaporation of the water. Cold prolongs open time.

**Humidity:** In the case of emulsion adhesives, humidity increases open time by slowing the evaporation of water.

**High absorbent substrates:** High absorbents shorten open time by absorbing more adhesive.

Initial tack is an adhesive's ability to hold the flooring in place as soon as it is installed, so that it does not lift or move. Sufficient initial tack is particularly important for difficult areas such as seams, edges, end-curl, etc. If the adhesive does not have enough initial tack, the material will lift after being installed and the installer will have to roll the area again and/or may have to weight the area down until the adhesive has set.

When an adhesive is first spread, it has little tack, but the tack increases along with the tackifying time.

Setting mechanism is the process in which an adhesive begins to cure.

### Setting mechanisms include:

**Catalyst:** One part of a two-part adhesive that, when combined, reacts and hardens. Our Altrofix 30 and 31 are two-part polyurethane adhesives consisting of a resin (part A) and a catalyst (part B).

**Setting stages:** There are several stages of setting. See diagram below.

**Adequate:** When the work site can be opened to light foot traffic (in general, a few hours after application, except in the case of reactive adhesives).

**Complete:** When the adhesive has acquired 90% or 100% of its maximum properties, including its maximum pull strength. At this stage, the heat can be turned back on without risk of the material lifting and in the case of wet areas, the floor covering can be thoroughly washed with water if required.

**Substrate permeability:** When selecting an adhesive, the absorbency of the substrate must be taken into account.

**Porous material on a porous substrate:** This is no problem, since the water can evaporate from both sides.

**Non-porous material on a porous substrate:** Excess water will be absorbed into that substrate.

**Non-porous material on a non-porous substrate:** The water MUST be totally evaporated before the material is installed. If not, the adhesive will never set and the water trapped inside may cause blistering or bubbling.

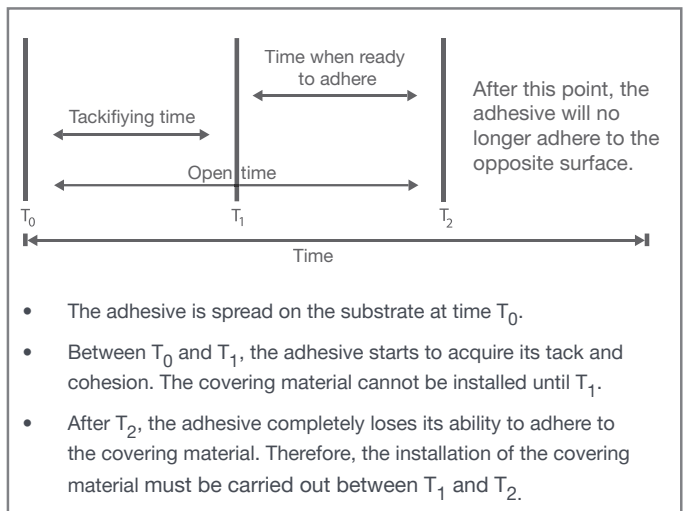

Another solution is to use a reactive adhesive (two-part polyurethane, AltroFix 30/31), which does not require evaporation to set.



# Chapter 7

## General sheet vinyl installation procedures

---

### Topics

- 7.1 General recommendations 31
- 7.2 Subfloor preparation 31
- 7.3 Cutting, fitting and laying 31
- 7.4 Sheet floor seaming 32
- 7.5 Adhesive application 32
- 7.6 Flash coving 33
- 7.7 Forming corners 33
- 7.8 Seam grooving 36





Notes

## 7.4 Sheet floor seaming

- Do not butt factory edges.
- Trim the factory edge in order to remove the edge-curl created during roll storage. Trim a minimum 1/2" (1.25cm) off all seam edges.
- Place material into position and overlap the seam edges 1" (25mm).
- All seams must be cut to fit "net" and not pressure fitted or gapped.
- Altro floor covering seams may be trace cut using a scoring blade followed by the a hook blade. Use the trimmed edge as a guide.
- Seams may also be hinged scribed (underscribed) if desired.
- You may straight edge and butt short seams such as doorways.
- For products with wood visuals, we recommend all seams be run parallel to the running pattern of the flooring. Cross joints should be avoided where possible as these will stand out against the natural wood pattern of the flooring.

Note: See product specific QuickFacts for additional information.

## 7.5 Adhesive application

### Two-Part Polyurethane Adhesives

Note: Allow polyurethane adhesives a minimum open time of 10-15 minutes but no more than necessary after spreading.

- Install Altro floor covering into adhesive following adhesive label's application instructions, taking care not to trap any air between the flooring and the subfloor.

Note: Take all necessary precautions to prevent the formation of air bubbles. Spread the adhesive so that the trowel ridges run straight and uniform across the sheet width. For products with wood visuals, spread the adhesive with the grain of the wood.

- Immediately roll the flooring from side to side in the direction of the adhesive ridges using a 100 lb (45kg) roller to ensure complete contact of flooring material to the adhesive and ensure air is completely removed from between the back of the Altro floor covering and the subfloor. Roll again lengthwise. Roll again in one hour. Check for and remove air pockets.
- Expel all trapped air with the use of a flat wooden or Perspex trowel and or a 100 lb (45 kg) roller. Weights such as sand bags must be placed over seams or around drains or in areas where pressure is required to keep the back of the Altro floor covering into the adhesive until the adhesive has set.

Note: When using one-part adhesive such as EcoFix+ with wood visual products, the adhesive must be spread with all trowel ridges running in the same direction as the wood grain.

## 7.6 Flash coving

When flash coving, wall surfaces should be sound, solid, smooth, dry, clean, and free of foreign substances.

- After sub-floor preparation, install cove stick and cap strip as specified. Follow specifications of contract documents for wall cap detailing when coving up walls. C7, Stainless Steel, Aluminum or standard cap from other manufacturers are inappropriate caps to use in wet applications. In all wet floor and wall applications (showers, kitchens, cart wash areas, etcetera), the overlap detailing method is the recommended and preferred finishing method, although C4 or C8 cap can be used when an appropriate wall cladding is also specified and used.
- Apply contact tape to the areas being covered per tape manufacturers' instructions.
- Install the Altro Sheet floor covering tightly down and onto the cove stick and trim the flooring to the cap as required.
- Fit floor covering into cap strip and roll with a hand roller.
- Always seal top of cap with appropriate caulking.

Notes \_\_\_\_\_

\_\_\_\_\_

\_\_\_\_\_

\_\_\_\_\_

\_\_\_\_\_

\_\_\_\_\_

\_\_\_\_\_

\_\_\_\_\_

\_\_\_\_\_

\_\_\_\_\_

\_\_\_\_\_

\_\_\_\_\_

\_\_\_\_\_

\_\_\_\_\_

\_\_\_\_\_

\_\_\_\_\_

\_\_\_\_\_

\_\_\_\_\_

\_\_\_\_\_

\_\_\_\_\_

\_\_\_\_\_

\_\_\_\_\_

\_\_\_\_\_

\_\_\_\_\_

\_\_\_\_\_

\_\_\_\_\_

\_\_\_\_\_

\_\_\_\_\_

\_\_\_\_\_

\_\_\_\_\_

\_\_\_\_\_

\_\_\_\_\_

\_\_\_\_\_

\_\_\_\_\_

\_\_\_\_\_

\_\_\_\_\_

## 7.7 Forming corners

### Forming an internal corner

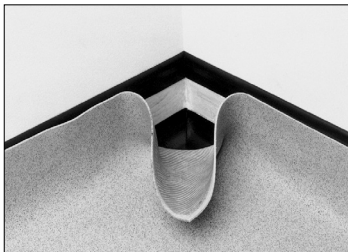

1. After warming the material, push the floor covering as far as possible into the internal corner.

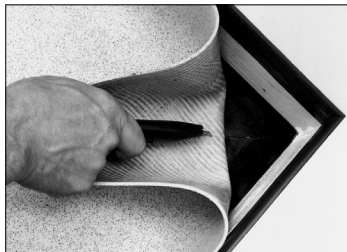

2. Make a cut from the base of the material to the top of the floor covering in line with the corner.



3. Fold in one side and gradually cut off the surplus material to complete the first part of the corner.

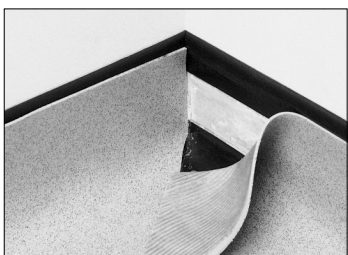

4. Fold in the second side.



5. Gradually trim the surplus material to achieve a net fit

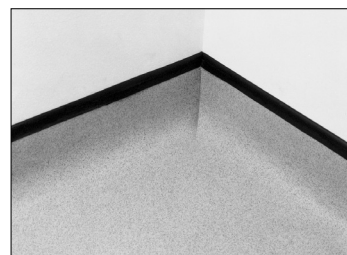

6. Heat weld to complete the section. See Heat welding on page 36 for more info about heat welding.

\_\_\_\_\_

Notes

### Forming an external corner using a butterfly piece – recommended

Note: A butterfly piece, also called a V-plug, is recommended for safety floor installations where traffic is expected to impact outside corners.

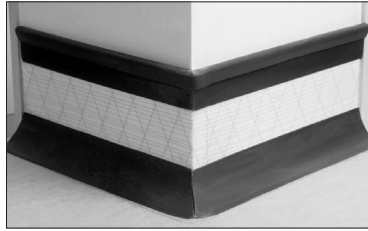

1. Install cap strip and cove stick using approved contact tape. The outside miter on the cove stick must be rounded at the subfloor line then shaped to match the radius of the cove stick.

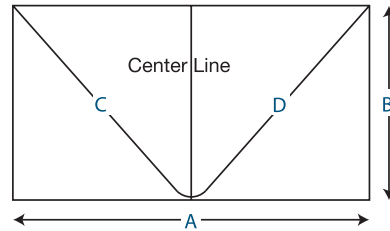

2. To cut a butterfly piece:

(i) Cut a rectangle from a scrap of the floor material.

$A = \text{height of the cove} \times 2$

$B = \text{distance from the top of the cap strip to half way down the radius of the cove stick.}$

(ii) Cut along lines C and D to make a triangle. Round the bottom point to the radius of a penny.

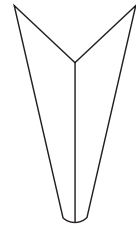

3. Folding a butterfly piece:

(i) Warm the back of the butterfly fill piece along the center line.

(ii) Fold the fill piece flat, back to back and along the center line.

(iii) When cool, open to 90°.

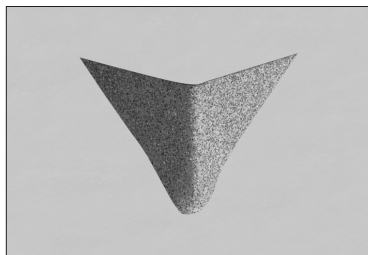

4. Finished butterfly piece.

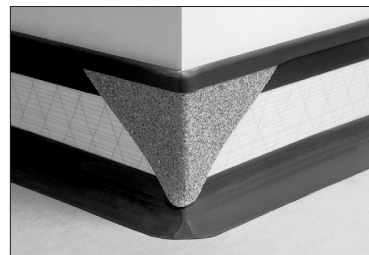

5. Place contact tape on the back of the corner. Fit the fill piece up under the lip of the cap strip and press into place.

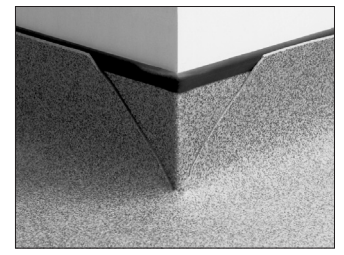

6. Once the butterfly corner fill is in place, the adhesive may be spread and the field material laid into position. The relief cuts must be made so the field material overlaps both edges and the bottom point of the butterfly corner fill.



7. Warm the material and ensure the field material is held firmly down against the cove stick while making the final cut.

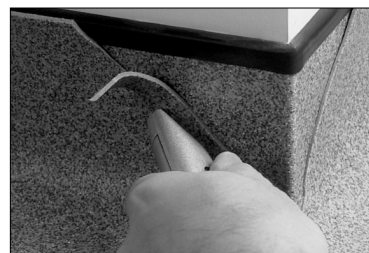

8. Using an Altro hook blade or concave blade, trim the field material to fit net to the perimeter of the butterfly corner fill.

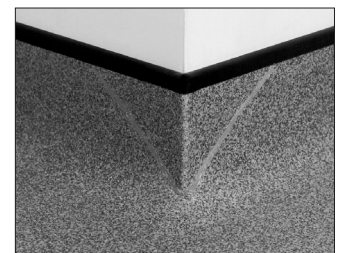

9. Groove and heat weld to complete the section.



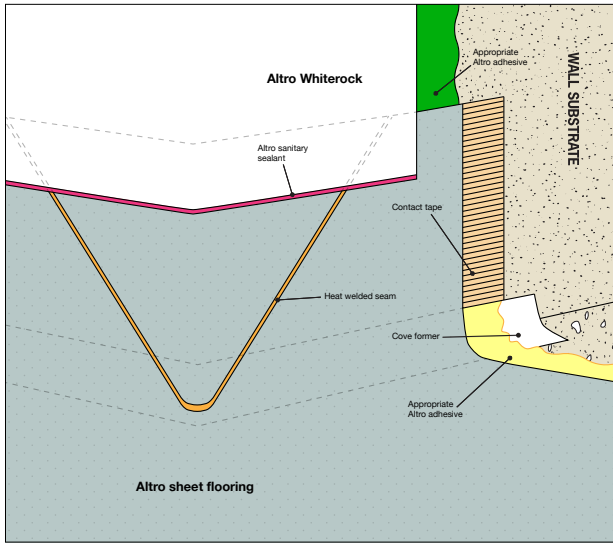

Butterfly corner(external v-plug) overlap transition

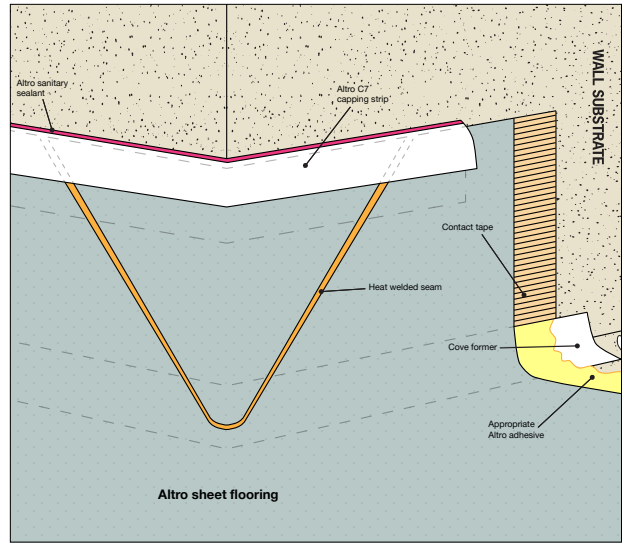

Butterfly corner(external v-plug) with C7 cap strip

## 7.8 Seam grooving

After Altro floor covering has been cut in and adhesive is properly set (usually the next day), seam grooving can begin.

Refer to grooving depth chart for recommended depth of groove. The groove must be cut equally along the seam using an Altro Hand Grooving Tool and straightedge. Alternatively, special power grooving blades are available.

Due to the metal particles in the Altro safety flooring, do not use standard grooving blades as the blades will dull very quickly.

Power grooving should only be accomplished by using a machine equipped with an Industrial Diamond Tipped Blade designed for Altro safety flooring.

Set the grooving machine to make a channel. Line up the grooving machine indicators with the center of the seam and push the machine along the seam.

Practice on a scrap piece of material before grooving the installed material to ensure the correct depth is set for the grooving machine.



Grooving depth based on flooring		
Non-PUR	Altro Stronghold 30 - 3.0mm	75%
	Altro Atlas 40 - 4.0mm	75%
	Altro Classic 25 - 2.5mm	75%
	Altro Marine 20 - 2mm	75%
PUR treated	Altro Aquarius - 2.0mm	90%
	Altro Illustra - 2.0mm	30-40%
	Altro Illustra AF - 2.4mm	70%
	Altro Reliance 25 - 2.5mm	90%
	Altro Walkway 20 - 2.0mm	90%
	Altro XpressLay - 2.2mm	70%
	Altro Cantata - 2.0mm	70%
	Altro Symphonia	70%
	Altro Orchestra	30-40%
	Altro Promenade	30-40%
	Altro Operetta	30-40%
	Altro Serenade	30-40%
	Altro Wood	30-40%
	Altro Wood Comfort	30-40%
	Altro Wood Acoustic	30-40%
Altro Wood adhesive-free	70%	
Altro Zodiac Smooth	30-40%	



# Chapter 8

## Heat welding

---

### Topics

8.1 Welding seams 38

8.2 Trimming seams 38

8.3 Welding corners 38



## 8.1 Welding seams

After all seams have been grooved, heat welding can begin. All seams and corners must be grooved heat welded with weldrod. When welding traditional safety flooring use a 4mm speed tip. For all of our non safety flooring a 4mm narrow flow tip should be used. Weldrod is supplied in colors to suit the floor covering being used. Wait overnight for adhesive to set before welding.

This wait period is not required for our adhesive free products.

### Preparation

- Ensure the heat welding nozzle is free of debris by cleaning the inside of the barrel with a wire brush before each weld.
- Make certain the heat welding gun is between 482°F (250°C) and 662°F (350°C). Test on scrap pieces of material to ensure complete melting and fusing of the heat-weld rod and floor material and to ensure that a smooth and uniform heat-weld can be achieved without burning (the final speed of heat-welding and temperature setting will need to be determined through practice). Ensure the weldrod is cut to the correct length for the seam to be welded and that it will not catch on any objects in the area.

### Welding

- Move the welding gun along the grooved seam with the weldrod feeding through the nozzle at the predetermined speed and temperature.
- Do not lean the gun to the right or left. Keep the foot of the nozzle parallel to the floor surface.

## 8.2 Trimming seams

### Horizontal areas

In flat areas, trimming of the weldrod should be carried out in two stages:

- Place a trim plate over the weldrod and trim off the top layer of the weldrod with the spatula knife. This can be done while the weldrod is still warm.
- When the remaining weldrod has cooled, trim the excess weld flush with the flooring surface using a spatula knife (without the trim plate).

### Corners and vertical covered areas

Use X-ACTO blades to trim cooled weldrod in corners and covered areas.

### Altro Marine 20 safety flooring

After heat welding Altro Marine 20, use a Slim Trim Chisel, with a straightedge as a guide, to trim the excess weldrod. For questions please contact Technical Services.

## 8.3 Welding corners

To weld internal and external corners, turn the nozzle at the end of the welding gun to the “up” position which allows for an easier starting point and proceed as shown. Once all the welding on the covered sections is completed, turn the high speed nozzle to the “down” position and heat weld the grooved floor seams.

A feed roller may be used in lieu of a welding tip when heat-welding corners and certain other hard to access areas of heat-welding.

### Welding an internal corner



1. All internal corners must be grooved before heat welding.



2. The X-ACTO small round router blade should be used for trimming the cooled weldrod on internal corners.



# Chapter 9

## CeGe<sup>®</sup> Green cold welding

---

### Topics

9.1 CeGe<sup>®</sup> Green instructions 41

## 9.1 CeGe® Green instructions

CeGe Green does not contain any volatile solvents, making it an environmentally friendly mixture for cold welding applications. This removes the need for a respiratory mask; however, the mixture is classified in the same category as household dish soap as unsafe for digestion and may cause skin and eye irritation on contact.

Note that CeGe Green is not flammable and does not have any restrictions for transport or storage. There is no risk of fumes catching fire during installation or following the product's use.

CeGe Green has been proven to increase the effectiveness of flooring installation. Its longer period of solidification compared to similar products allows the mixture to be applied at the same time the flooring is installed, and for final adjustments to be made before it completely solidifies. This offers a considerable advantage over alternatives that require waiting until the next day to complete welding. You can also remove potential spills and surplus without any detrimental effect to the floor's surface.

An opened tube can be resealed and used again at a later date after initial application. The container is devoid of specialized nozzles, meaning that the product will not dry out or clog after its first opening.

Altro recommends waiting at least one day until placing weight on the flooring joint following application of CeGe Green. The strength of the joint increases over time and reaches its full strength after one to four weeks, making it comparable to heat-welded joints.

### Coverage guide

Approx. coverage 65-82 linear feet (20-25 linear meters) per 50 mL tube.

CeGe Green only to be used in dry environments with these products

Altro Symphonia
Altro Operetta
Altro Orchestra
Altro Serenade
Altro Illustra
Altro Wood
Altro Wood Comfort
Altro Wood Acoustic

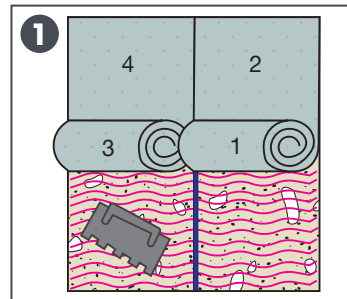

- Dry fit and cut in sheet vinyl
- Roll up parts 1 and 3
- Place 1/2" tape on the substrate at the seam location
- Glue the floor from 1 to 3
- Remove the tape

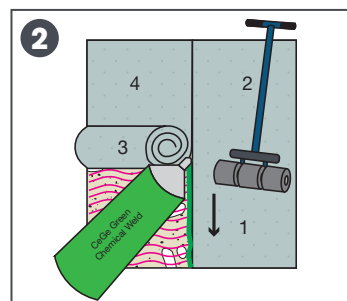

- Install and roll part 1 with a roller.
- Apply CeGe Green alongside the edge of part 1

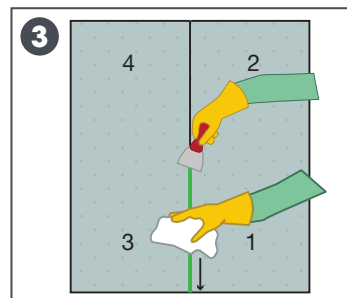

- Install part 3
- Roll with a roller along the joint
- Remove surplus with a small putty knife, followed by a damp cloth
- Repeat steps 1, 2 and 3 with parts 4 and 2

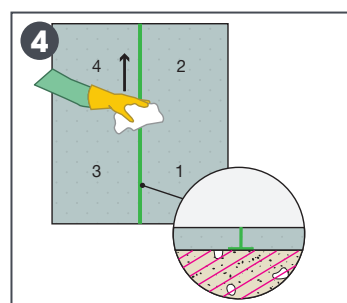

- Inspect and roll with a roller over the joints one more time

# Chapter 10

## Drains and cleanouts

---

### Topics

- 10.1 ICC-ES PMG product certification 43
- 10.2 New round drains, cleanouts, trenches and floor sinks 44
- 10.3 Modifying an existing drain or cleanout 47
- 10.4 Installation of gulley edge/angle 48

Cutting the flooring material up to, or around, a drain, cleanout, trench drain, and other plumbing fixtures, is not a recommended installation method and will void the Altro Warranty. Please refer to the this section of the Altro flooring installation guide for the correct detailing or contact Altro technical services.





Notes

## 10.2 New round drains, cleanouts, trenches and floor sinks

For Altro sheet flooring to be successfully installed in wet areas (i.e. kitchens, showers, bathrooms, etc) all penetrations must be detailed properly to prevent moisture from leaking under the floor. This is done by mechanically fastening the flooring in place with surface membrane clamping plumbing fixtures. Altro safety sheet flooring shall be installed in accordance with published instructions and the applicable code(s). When provided, the floor drain must have a surface membrane clamp and shall comply with ASME A112.18.2/CSA B125.2 as applicable.

**CAUTION:** In many cases a drain body will have weep holes for use with a mid slab moisture membrane, which is typical for ceramic tile installations. We ask that if the specified drain body has weep holes that they be sealed as to not allow moisture from inside the drain itself from leaking back up and out the weep holes.

The following list of surface membrane clamping fixtures will aid in the design and specification of mechanical and plumbing fixtures. Please be advised that this list is constantly changing due to plumbing manufacturers updating/designing new surface membrane clamping fixtures.

Always consult with plumbing manufacturers for proper plumbing fixture selection.

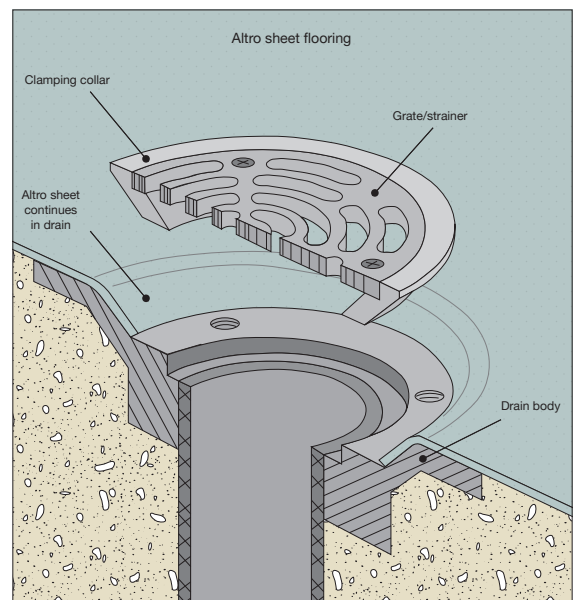
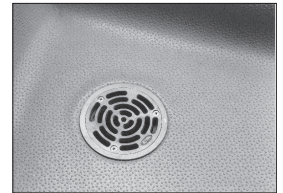
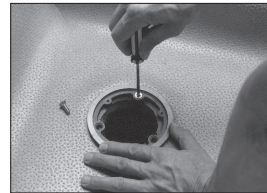
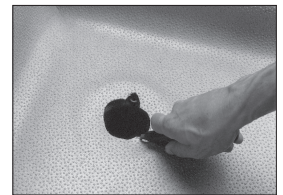
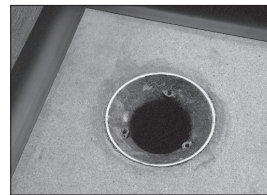
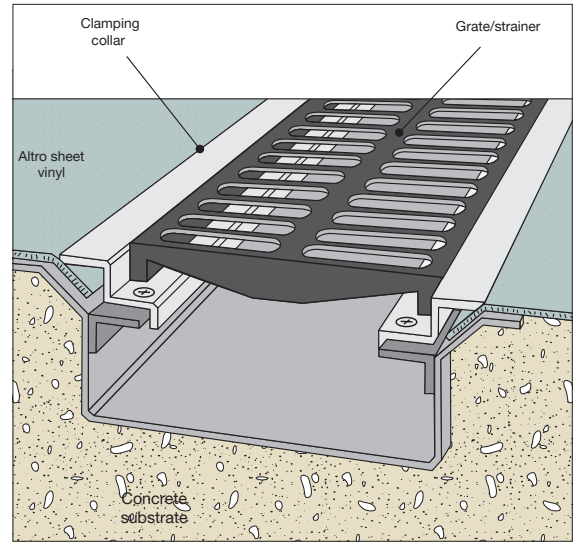





Notes

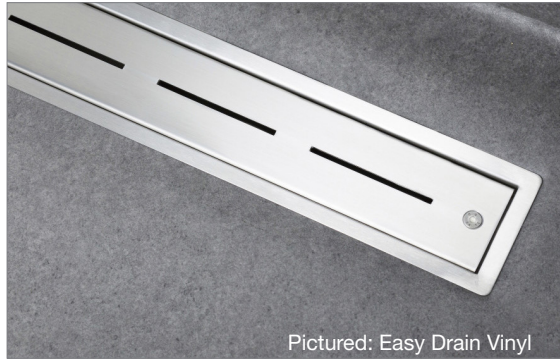

### Examples of surface membrane clamping trench/lineal drains

Trench and lineal drains are commonly used in commercial kitchens and showers. Many plumbing manufacturers are able to make custom size surface membrane clamping trench/lineal drains.

#### Examples of surface membrane clamping trench/lineal drains:

- [Easy Drain Vinyl](#)
- [Blücher BWS-200](#)
- [IMC/TEDDY - AFT](#)

#### Ligature-resistant drain:

- [Blücher BWS-300](#)



### Examples of surface membrane clamping flooring sinks

Floor sinks are primarily used in kitchens and laboratories. While porcelain floor sinks are commonly used and specified, these are NOT a surface membrane clamping style that Altro recommends. Altro gulley edge/angle is required to be fit and installed around a porcelain floor sink. Gulley edge/angle cannot be used on wood substrates. See our flooring installation guide for more information on installing Altro gulley edge/angle on [altro.com](http://altro.com).

#### Examples of surface membrane clamping floor sinks:

- [Josam 45130](#)
- [Zurn Z1755](#)

## 10.3 Modifying an existing drain or cleanout

- Remove the drain strainer or cleanout cover plate.
- With a quality moisture tolerant and resistant patching compound, finish the subfloor flush with the drain perimeter.

NOTE: If drain body is higher than the concrete surface, it must be either ground-off or chipped out and lowered. If the drain body is lower than the concrete surface, you must slightly grind the concrete surface to allow for a slight slope-to-drain profile. Follow all applicable local, state, and federal regulations and laws pertaining to saw cutting, grinding, and patching work of concrete; all work is to comply with OSHA 3902 Respirable Crystalline Silica Standard.

- Using a small hand held electric grinder and/or bench grinder to slightly remove the square shoulder on the inside edge of the drain body to create a smoother edge into the drain into the drain. (See Diagram A.)
- Similarly, remove the square shoulder from the perimeter of the backside of the drain cover plate creating a 45-degree slope to match the drain body. (See Diagram B.)
- Replace the cover plate screws for the purpose of land marking the screw holes and preventing the adhesive from filling the holes during the gluing process.

### Gluing and cutting process

- Apply adhesive (AltroFix 30 two-part polyurethane or AltroFix MP600) on the floor, around, and onto the sloped perimeter of the drain
- Place the Altro floor covering over the drain, and fit cut only to the inside diameter of the drain plate screws.

Note: Cutting to the outside of the screws will cause the material to be short of the drain plate once it is re-installed.

- Cut small windows in the Altro floor covering at the drain plate screws only.
- After all final fitting is completed, warm material with a hot air blower and secure the drain plate cover in place. This process pinches the Altro floor covering between the drain body and the drain plate cover. (See Diagram C, completed drain.)

Diagram A

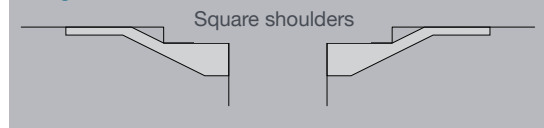

Diagram B

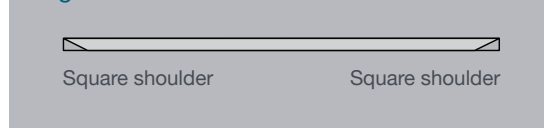
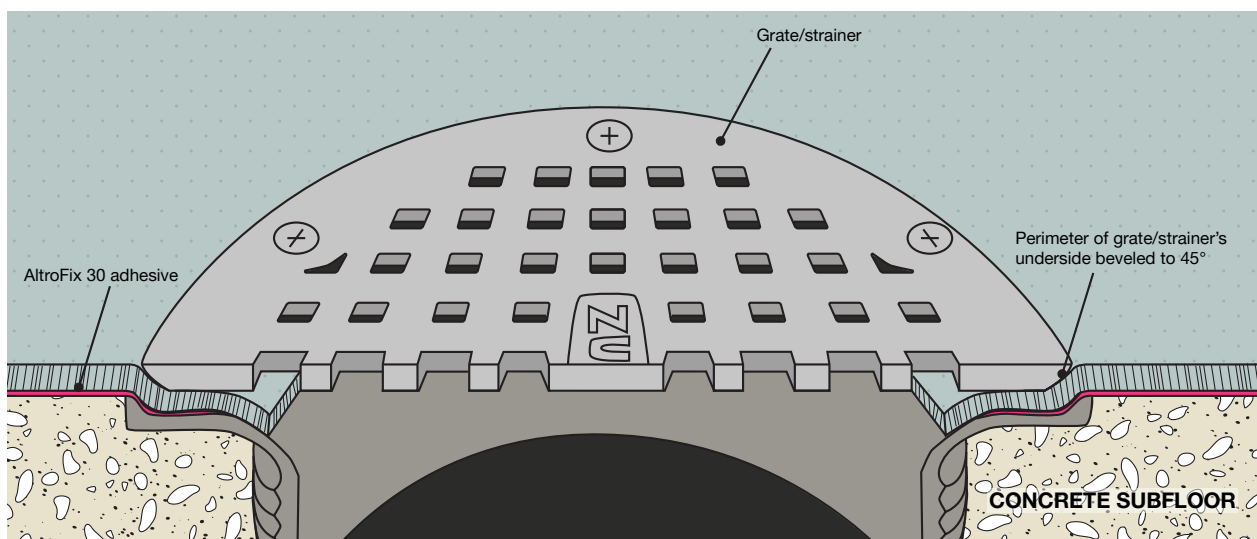
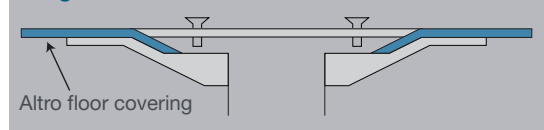

Diagram C



**Note:** In most cases, it will be necessary to weigh down the drain area to allow the adhesive to set-up.

**Caution:** Failure to weigh down the drain area during this process may cause a bubble or a pucker in the Altro floor covering, to which there is no remedy.

Approval from the General Contractor/owner must also be obtained before commencing with this procedure.

Altro floor covering must be mechanically fastened to all drain outlets and cleanouts to ensure a permanent watertight installation as outlined in this section.

## 10.4 Installation of gulley edge/ angle

### Cutting the concrete

Saw cutting and gulley edge and angle are not to be used in wood subfloors.

- Using a small hand held electric grinder, tuck point grinder, circular saw or other appropriate saw equipped with a diamond saw blade (wet type preferred), cut a 1" deep x 3/32nd" wide saw cut in the concrete substrate to receive the gulley angle/edge. Two (2) passes may be necessary to achieve the correct width of groove unless the saw blade is 3/32nd" wide. Note: The use of wet type saw blade would, if used correctly, reduce the amount of airborne dust created

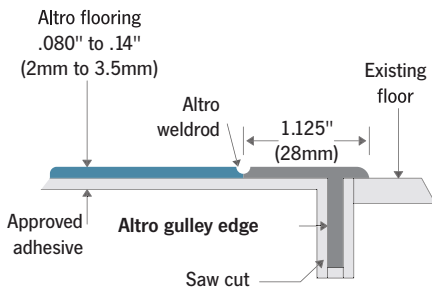

0.75" (20mm) deep x 0.16" (4mm) wide  
Install gulley edge using AltroFix MP600 adhesive or approved polyurethane

while cutting concrete. Dry cutting can be done if a dust recovery cutting system is utilized. In some instances using two blades side by side on the angle grinder to achieve the required width of the saw cut may be necessary to do this in one pass. The use of a wet sponge held beside the blade guard along with the use of a HEPA vacuum system must be used. \*Follow all applicable local, state, and federal regulations and laws pertaining to saw cutting, grinding, and patching work of concrete; all work is to comply with OSHA 3902 Respirable Crystalline Silica Standard.

- If the area to be saw cut is in a doorway or abutting a wall, the saw/grinder will be unable to cut all the way to the door casing or wall. In this case a series of 1" deep holes may be drilled in the concrete substrate using a 3/32nd" masonry drill bit and then chiseled out to allow gulley angle/edge to seat flush with the subfloor. You may also cut back the leg of the angle/edge to be inserted within 1" of the ends.
- If the area to be saw cut is at floor drains or trenches, the cut must be directly up against the drain or trench.
- On all types of cuts, it's helpful to use some form of straight edge or guide to create a straight saw cut allowing for a professional fit and finish.
- All water and concrete silt must be removed/vacuumed from the saw cut. The area in and around the saw cut must be allowed to dry completely before gluing can take place

### Gluing process

- Using masking tape, outline the outside of perimeters of where the Gulley edge/angle will be installed, this will aid with the cleanup of excess adhesive after installing the gulley edge.
- Apply AltroFix MP600 on the floor and in the saw cut.
- Place the gulley angle/edge into the saw cut making certain that the strip is completely embedded into the adhesive.
- Using a small scraper or putty knife, remove excess adhesive. If adhesive is on the surface of the gulley edge, remove using a small amount of Isopropyl alcohol on a clean white rag. Note: Do not allow adhesive to dry on the gulley edge. Once dry, the 2-part adhesive cannot be removed.
- It may also be necessary to weight down the gulley edge until the adhesive has a chance to set-up. This will ensure that the strip is fully seated and without voids.
- Always allow the gulley edge to set up in the adhesive prior to cutting and fitting the Altro safety flooring to the newly installed strip. The flooring material should be scribe fit to ensure a neat net fit seam for heat welding.

### Welding process

- Heat-welding the new flooring to the edging must not be attempted until adhesive has cured (typically 24 hours on AltroFix 30 and four to six hours on the AltroFix 31).
- Groove gulley edge and flooring as if it were a seam in the flooring material, gulley edges are made of vinyl and weld just like the flooring material. Note: When hand grooving, always use a straight edge as a guide to achieve a straight groove.
- Clean all dirt and debris from grooved seam and weld as you would the Altro flooring material. If applicable, always weld mitered corners with a black rod. Note: Traditionally a black rod is used to weld the flooring to the gulley edge. However, a rod color that matches the flooring material can also be used.
- Once the welding rod is allowed to cool (typically 30 minutes) trim with a sharp trimming knife using a trim plate for the initial cut followed by the trimming spatula for the final flush cut.
- Touch-up can be done using a hot tip repair tool or bullet tip repair tool.

Note: gulley edge must be fully adhered both inside the saw cut groove and onto the substrate. All joints, flooring to gulley edge as well as corners of the gulley edge must be welded. Failure to do so may allow water to encroach compromising the integrity of the flooring and gulley edge.



# Chapter 11

## Installing in cold environments

---

### Topics

11.1 Freezers and coolers 51



# Chapter 12

## Repairs and maintenance

---

### Topics

10.1 Repairs 53

10.2 Maintenance for sheet vinyl 53

10.3 Recommended maintenance products 55



## 10.1 Repairs

A regular repair and maintenance program should be adopted to identify areas of damage during the life of the floor.

### Areas to check regularly include:

- Welds
- Drains
- Seals around abutments
- Other areas showing damage

Damage to Altro flooring should be repaired as quickly as possible.

AltroFix MP600 adhesive, and Altro EcoFix 65 spray adhesive are recommended for repairs. AltroFix 30/31 may also be used.

Cuts in the flooring must be heat welded immediately in order to create a seal against moisture intrusion.

There are specific recommendations as to how best to accomplish certain repairs. Please contact Altro Technical Department to discuss these.



AltroFix MP600



Altro EcoFix 65 Spray

## 10.2 Maintenance for sheet vinyl

**Develop a regular cleaning program suited to the usage and traffic of the area** - Heavily trafficked or highly visible areas need to be cleaned more often than areas which are seldom used, or where appearance is less important. The best and most cost effective method of cleaning Altro flooring is by an auto scrubbing machine. Care should be taken to select the correct pad.

**Use recommended cleaning chemicals** - Use only recommended cleaning products or their equivalent in the correct dilution. Do not mix two different cleaning products together, and always follow the manufacturer's instructions. Always check the suitability of cleaners for use on vinyl floors. Do not use cleaner containing pine oil, phenolic sanitizer, or enzyme cleaners. All chemicals must be thoroughly rinsed from the flooring and no residues are to be left on the surface of the flooring.

**Remove scuff marks regularly** - To remove any rubber heel marks by abrasion use the correct machine pad, or scrub by hand. For areas requiring renovation due to neglect or heavy soiling consult Altro Technical Services.

**Protect newly installed floors** - All newly installed Altro flooring should be covered and protected from all other trades with a suitable non-staining protective covering, such as Masonite™ or Ram Board®.

**Dirt control** - 80% of the dirt in a building is carried in on shoes. A suitable dirt excluder and clean zone outside all entrances and a mat inside just prior to the flooring will protect the flooring. Mats should be regularly cleaned to maintain their effectiveness. Dust control mops are also useful.

**Altro Marine 20** - Normally used in shower and pool surrounds, a deck brush or scrubber brush is recommended over pads and mops. A specialty cleaner, such as CLR™, may be required occasionally to remove hardened lime deposits.

Some materials are known to cause staining on vinyl floors.

### Typical examples include:

- Asphalt and bitumen materials
- Cardboard/Hardboard (wet)
- Fire treatment and maintenance materials used on carpets could transfer to vinyl flooring and cause staining
- Permanent markers and ink
- Spray paint
- Dyes from printed literature or packaging
- Rubber-backed carpets and rubber mats
- Rubber furniture rests and wheels
- Shoe soles not made from non-staining materials
- Heat degradation
- Some chemicals in non-approved and non-tested or non-recommended cleaners may cause staining or other damage, always consult with the cleaning chemical manufacturer and supplier for all assurances of suitability.

Notes

## 10.2 Maintenance for sheet vinyl (cont.)

### Initial maintenance

1. For glue down floors do not begin any maintenance procedure for at least 72 hours after installation. For our Adhesive Free Loose Lay Floors one of the many benefits is that they can be heat-welded, cleaned and maintained immediately after installation as there are no adhesives requiring drying and setting time.
2. Sweep or vacuum floor surface to remove all loose dust and debris.
3. Apply diluted\* AltroClean 44™ to the floor. Allow to sit for five minutes to allow the cleaner to attack the surface soil.
4. Scrub floor with an automatic scrubber (3 in 1 machine) or a standard low speed swing machine (150rpm to 350rpm) fitted with an Altro Unipad™.
5. If using a standard low-speed swing machine, remove wash water with a wet vac.
6. Ensure the floor is thoroughly rinsed with fresh, clean water. No cleaning residue should remain on the floor.
7. Allow surface to dry before use.

\* For AltroClean 44 the dilution rates depend on the condition of the floor. For moderate soiling use a 1:40 dilution ratio. For heavy soiling use 1:10.

### Routine machine maintenance

8. Sweep and/or vacuum floor surface to remove all loose dust and debris.
9. Apply diluted\* AltroClean 44™ to the floor. Allow to sit for five minutes to allow the cleaner to attack the surface soil. DO NOT flood the floor unless the flooring system was designed for holding water and was installed per Altro's Detailing guide for wet environments. Always allow the adhesive to dry and cure before flooding any floor.
10. Scrub floor with an automatic scrubber (3 in 1 machine) or a standard low speed swing machine (150rpm to 350rpm) fitted with an Altro Unipad™.
11. If using a standard low-speed swing machine, remove wash water with a wet vac.
12. Ensure the floor is thoroughly rinsed with fresh, clean water. No cleaning residue should remain on the floor.
13. Allow surface to dry before use.

### Routine manual maintenance

14. Sweep and/or vacuum floor surface to remove all loose dust and debris.
15. Apply diluted\* AltroClean 44™ to the floor. Allow to sit for five minutes to allow the cleaner to attack the surface soil. DO NOT flood the floor unless the flooring system was designed for holding water and was installed per Altro's Detailing guide for wet environments. Always allow the adhesive to dry and cure before flooding any floor.
16. Scrub floor with a rectangular Altro Unipad or a deck brush attached to a mop handle.
17. Remove wash water with a wet vac, rough floor mop using a double bucket or squeegee toward a drain.
18. Ensure the floor is thoroughly rinsed with fresh, clean water. No cleaning residue should remain on the floor.
19. Allow surface to dry before use.



